



# Accessible Parking

Rebecca Rabatin

February 21, 2025

1

1

## Webinar Series: Wisconsin ADA Coordinators Association

### Disclaimer

This webinar hosted by the Wisconsin ADA Coordinators Association is not meant to be legal advice. Although we may refer to the Americans with Disabilities Act (ADA) or similar state and local laws, this presentation is provided as an educational resource. Our goal is to give public entities a framework for accessibility and providing accommodations or modifications. We encourage attendees to seek guidance about their obligations from their own legal counsel.

2

2

## Presenter

### **Rebecca Rabatin**

Community Access and Legislative Policy Analyst  
Independence First

[rrabatin@independencefirst.org](mailto:rrabatin@independencefirst.org)

414-226-8307

3

3

## Webinar goals

- Outline different parking options
- Review scoping and technical requirements under the Americans with Disabilities Act (ADA) Accessibility Standards for parking facilities.
- Review scoping and technical requirements under the Public Right-of-Way Accessibility Guidelines (PROWAG) for on-street parking.
- Review Wisconsin Statutes on accessible parking.

4

4

# Accessible Parking under the ADA Accessibility Standards

5

5

## When are Accessible Parking Spaces Required?

Each facility that provides parking

- Structures or lots
- Public, employee, restricted or valet parking
- Residential

Exceptions:

- Parking exclusively for buses, trucks, other delivery vehicles, law enforcement vehicles, or vehicular impound
- New parking services due to Covid??

6

6

# Scoping Requirements

**Table 208.2 Parking Spaces - General**

Total Number of Parking Spaces Provided in Parking Facility	Minimum Number of Required Accessible Parking Spaces
1 to 25	1
26 to 50	2
51 to 75	3
76 to 100	4
101 to 150	5
150 to 200	6
201 to 300	7

Total Number of Parking Spaces Provided in Parking Facility	Minimum Number of Required Accessible Parking Spaces
301 to 400	8
401 to 500	9
501 to 1000	2 percent of total
1001 and over	20, plus 1 for each 100, or fraction thereof over 1000

\*\*For every six or fraction of six parking spaces required by Table 208.2, at least one shall be a van parking space.\*\*

## Scoping Requirements Parking Spaces – Hospital Outpatient Facilities

- 10% of patient and visitor parking spaces provided for the hospital outpatient facility.

Hospital Outpatient Facilities Advisory: Outpatient facility is intended to cover facilities or units that are located in hospital and that provide regular and continually medical treatment without overnight stays.

Doctors' offices, independent clinics, or other facilities not located in hospitals are not considered hospital outpatient facilities.

## Scoping Requirements

### Parking Spaces – Outpatient Physical Therapy Facilities

- 20% patient and visitor parking spaces provided to serve rehabilitation facilities specializing in treating conditions that affect mobility and outpatient physical therapy facilities.

9

9

## Scoping Requirements

### Parking Spaces – Residential

Where at least 1 parking space is provided for residents

- For each residential dwelling unit required to include mobility features, 1 accessible parking space .

Where more than 1 parking space is provided for residents

- 2% above the required 1 for each residential dwelling unit required to include mobility features.

Parking for guests, employees or non-residents

- Comply with requirements of Table 208.2

10

10

## Location of Accessible Parking Spaces General

- Locate on the shortest route to a facility's accessible entrance.
- Disperse spaces when there is more than one accessible entrance to a facility.
- Van accessible parking may be on one level of multi-story parking facilities.
- Locate on shortest accessible route to an accessible pedestrian route when not serving a particular facility.

11

11

## Location of Accessible Parking Spaces Not Serving a Particular Facility or Building

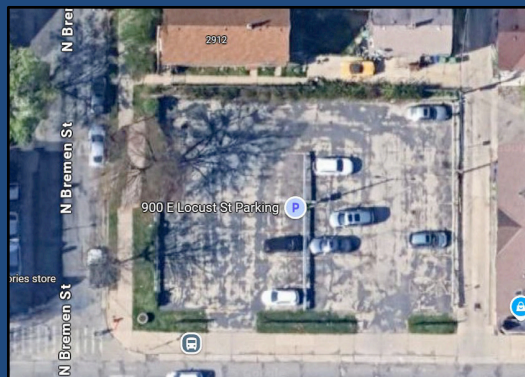

Parking spaces to be located on shortest accessible route to the pedestrian access route

12

12



## Location of Accessible Parking Spaces Residential

- Locate on shortest accessible route to residential dwelling units required to provide mobility features.
- Disburse parking on shortest accessible routes for guests and employees accessible parking.

15

15

## Accessible Parking Spaces Width and Length

- Car – 8 feet wide minimum and marked for the entire length
- Van – 11 feet wide minimum and marked for the entire length

Exception: van accessible parking space may be 8 feet wide if the adjacent access aisle is also 8 feet wide.

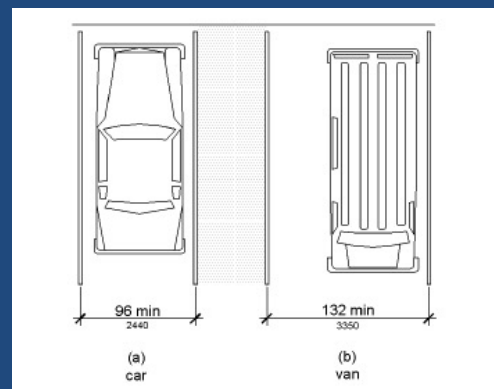

16

16



## Access Aisles Width and Length

- Minimum 5 feet wide or 8 feet wide if adjacent to an 8 feet wide van parking space.
- Access aisle to extend the entire length of the parking space. No tapering of access aisle.

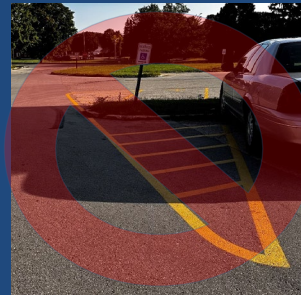
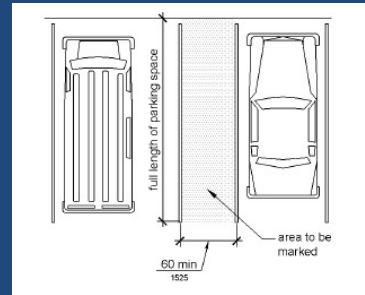

17

17

## Access Aisles Markings and Location

- Mark access aisle to discourage parking within the aisle. Markings of access aisles are to be measured from centerline to centerline.
- Access aisle are not to overlap the vehicular way.
- Locate access aisle on either side of vehicle except for angled parking spaces, the access aisle shall be located on the passenger side of the parking space.

Advisory: Consider locating access aisle on the passenger side of a van accessible parking space.

18

18

## Accessible Parking Space & Access Aisles Ground Surface

- Both accessible parking spaces and access aisles shall be firm and stable.
- Slopes are to be no greater 1:48 (or 2.03%) in any direction.
- Curb ramps to access pedestrian routes shall not project out into either the parking space or access aisle.



19

19

## Accessible Parking Space & Access Aisles Vertical Clearance

- 98 inches minimum clearance at entrance, vehicular route, van parking, and access aisle serving van parking.

Advisory: post signage at garage entrance informing drivers of vertical clearance and location of van accessible parking spaces.

20

20

## Accessible Parking Space & Access Aisles Identification

- Identify the accessible parking spaces and access aisles with signs that include the International Symbol of Accessibility (ISA).
- The bottom of signs are to post a minimum of 60 inches above the finished floor or ground surface.
- Include “van accessible” signage identifying van accessible parking spaces. Identifier is to posted below the accessible parking space but still 60 inches above the finished floor or ground surface.

21

21

## Accessible Parking Space & Access Aisles Identification (cont'd)

- Verbiage to be posted on accessible parking signs are determined under State Statutes.
- Painting of the ISA on the parking ground or floor surface is not compliant identification of accessible parking spaces and access aisles.
- Vehicles with proper disabled plates or tags may park in van accessible parking spaces.

22

22

## Accessible Parking Space & Access Aisles Relation to Accessible Route

- Parking spaces and access aisles shall be designed so that cars and vans, when parked, cannot obstruct the required clear width of adjacent accessible routes..

Advisory: Wheel stops are an effective way to prevent vehicle overhangs from reducing the clear width of accessible routes.

23

23

## On-Street Accessible Parking under the Public Right-of-Way Accessibility Guidelines (PROWAG)

24

24

## When are Accessible On-Street Parking Spaces Required?

- Accessible on-street parking is to be provided when on-street parking is provided and is metered or designated with signage or pavement markings.

### Exceptions:

- On-street parking designated for residential parking
- Commercial or law enforcement parking
- Only affected areas during alterations

25

25

## Scoping Requirements

### Table R211 On-Street Parking Spaces

Total Number of Metered or Designated Parking Spaces	Minimum Number of Accessible Parking Spaces
1 to 25	1
26 to 50	2
51 to 75	3
76 to 100	4
101 to 150	5
151 to 200	6
201 and over	4 percent of total

26

26

## Scoping Requirements Parking on Block Perimeter

- Where parking spaces are provided on a block perimeter and are metered or designated by signs or pavement markings, accessible parking spaces shall be provided in accordance with Table R211.
- Where parking is metered or designated by signs, but individual spaces are not marked, each 20 feet of block perimeter where parking is designated shall be counted as one parking space.

27

27

## Scoping Requirements Parking on Block Perimeter (cont'd)

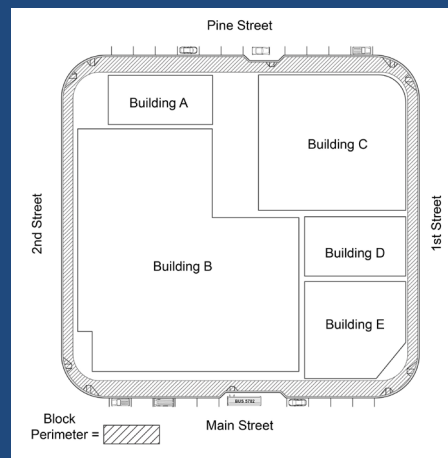

28

28

## Scoping Requirements Parking not on Block Perimeter

- Where parking spaces are provided on a section of a street that is not part of a block perimeter, accessible parking spaces shall be provided in accordance with Table R211.
- Where parking is metered or designated by signs or pavement markings, but individual spaces are not marked, each 20 feet of street where parking is designated shall be counted as one parking space.

29

29

## Parallel On-Street Parking Spaces

- Parallel on-street parking spaces shall be 24 feet long minimum and 13 feet wide minimum.
- Parallel parking spaces are to not encroach on to the vehicular.

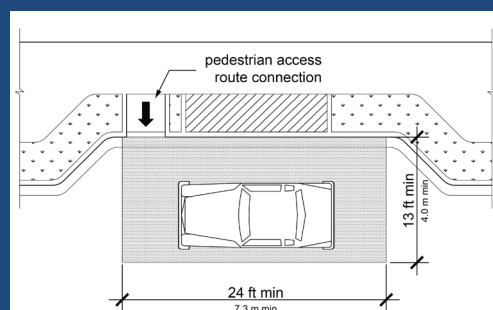

30

30

## Parallel On-Street Parking Spaces Exception 1 during Alterations

- Accessible parallel on-street parking spaces, adjacent to pedestrian circulation paths not being altered, may have the same dimensions as the adjacent parallel on-street parking spaces if they are provided nearest the crosswalk at the end of the block face or nearest a midblock crosswalk, and a curb ramp or blended transition is provided serving the crosswalk.

31

31

## Parallel On-Street Parking Spaces Exception 1 during Alterations (cont'd)

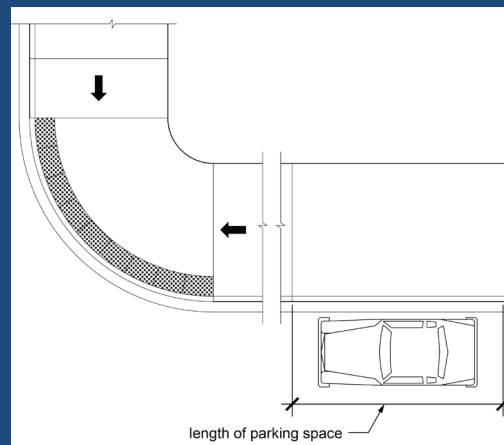

32

32



## Parallel On-Street Parking Spaces Exception 2 during Alterations

- Where providing parallel on-street parking spaces would result in an available right-of-way width less than or equal to 9 feet, measured from the curb line to the right-of-way line, the accessible parallel on-street parking spaces may have the same dimensions as the adjacent parallel on-street parking spaces if they are provided nearest the crosswalk at the end of the block face or nearest a midblock crosswalk, and a curb ramp or blended transition is provided serving the crosswalk.

33

33

## Parallel On-Street Parking Spaces Exception 2 during Alterations (cont'd)

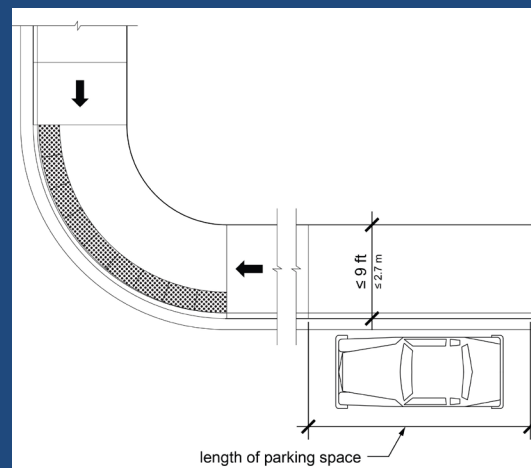

34

34

## Pedestrian Access Route Connection

- Parallel on-street parking spaces shall connect to pedestrian access routes.
- Where curb ramps and blended transitions are used, they shall not reduce the required width or length of the parking spaces and shall be located at either end of the parking space.
- Where two or more accessible parallel on-street parking spaces are contiguous on a block face, each accessible parallel on-street parking space shall have an independent connection to the pedestrian access route.

35

35

## Clearance Adjacent to Parallel Parking Spaces

The center 50 percent of the length of the sidewalk, or other surface, adjacent to an accessible parallel parking space shall be free of obstructions, including parking identification signs, parking pay meters, and parking pay stations, and shall meet the accessible pedestrian route surface requirements.

36

36

## Clearance Adjacent to Parking Spaces Cont'd

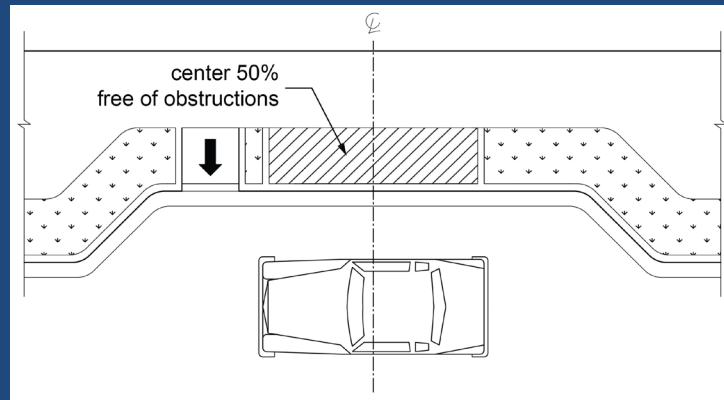

37

37

## Accessible On-Street Parking Spaces Identification

- Identify the accessible parking spaces and access aisles with signs that include the International Symbol of Accessibility (ISA).
- The bottom of signs are to post a minimum of 60 inches above the finished floor or ground surface.

38

38

## Accessible On-Street Perpendicular Parking Spaces

- Perpendicular on-street parking spaces shall be 13 feet wide minimum.
- Access aisles shall be 8 feet wide minimum extending the full length of the parking space.
- One access aisle shall be permitted to serve two parking spaces where front and rear entry parking are both permitted.
- Where an access aisle serves only one parking space and parking is restricted to either front entry or rear entry orientation, the access aisle shall be located on the passenger side of the vehicle.

39

39

## Accessible On-Street Perpendicular Parking Spaces (cont'd)

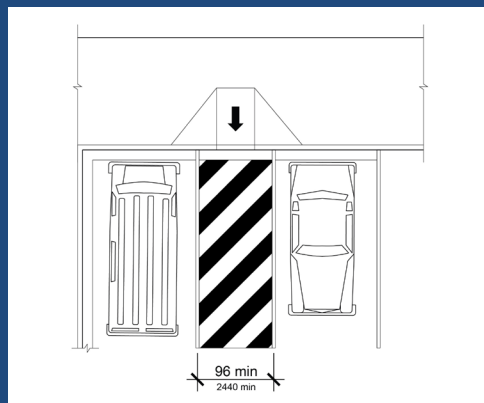

40

40

## Accessible On-Street Angled Parking Spaces

- Angled on-street parking spaces shall be 11 feet wide minimum.
- Each angled on-street parking space shall have an adjacent access aisle 60 inches wide minimum extending the full length of the parking space on the passenger side.

41

41

## Accessible On-Street Angled Parking Spaces (cont'd)

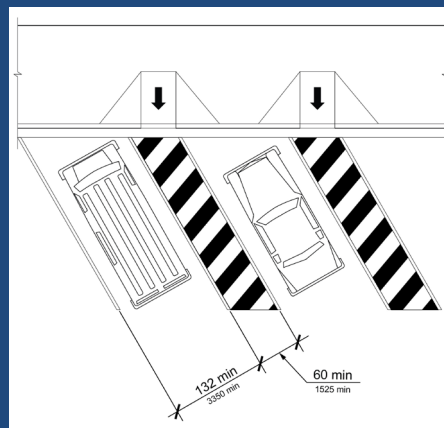

42

42

## Common Requirements for Perpendicular and Angled Parking Spaces

- Access aisle surfaces shall be marked to discourage parking.
- Access aisles to be located on the same level as the accessible parking space.
- Access aisles shall connect to pedestrian access routes.

43

43

## Common Requirements for Perpendicular and Angled Parking Spaces (cont'd 2)

- Where curb ramps and blended transitions are used, they shall not reduce the required width or length of access aisles and parking spaces.
- A detectable warning surface is not required on a curb ramp or blended transition used exclusively to connect on-street parking access aisles to pedestrian access routes.
- Parking spaces and access aisles shall have change in level no greater than 1:48 (2.03%)

44

44

## Common Requirements for Perpendicular and Angled Parking Spaces (cont'd 3)

- Perpendicular or angled on-street parking spaces shall be identified by signs displaying the ISA.
- The signs shall be located at the head of the parking space.
- Signs shall be 60 inches minimum above the ground surface measured to the bottom of the sign.

45

45

## Common Requirements for Perpendicular and Angled Parking Spaces (cont'd 4)

- Parking meters and parking pay stations that serve accessible parking spaces shall provide operable parts that do not require a twisting motion.
- A 30 inch by 48-inch clear space shall be provided for approach to parking meters and pay stations.
- Visibility of the parking meter or parking pay station shall be located 40 inches maximum above the center of the clear space in front of the parking meter or parking pay station.

46

46

# Wisconsin State Statutes Disabled Parking 346.503

47

47

## Scoping Wisconsin Statutes 346.503 (1m) (a)

The owner or lessee of any public building or place of employment and the owner or lessee of any parking facility which offers parking to the public shall reserve at least the following number of spaces for use by a motor vehicle used by a physically disabled person:

1. At least one space for a facility offering 26 to 49 spaces.
2. At least 2 percent of all spaces for a facility offering 50 to 1,000 spaces.
3. At least one percent, in addition to that specified in subd. 2., of each 1,000 spaces over the first 1,000 for a facility offering more than 1,000 spaces.

48

48



## When Required

### Wisconsin Statutes 346.503 (1m) (ag)

Any owner or lessee of any public building or place of employment, and to any owner or lessee of any parking facility that offers parking to the public, with respect to any parking area initially constructed, or reconstructed, resurfaced, or seal coated, on or after May 27, 1976.

49

49

## Disabled Parking Space Width

### Wisconsin Statutes 346.503 (1m) (b)

- Parking spaces reserved under this subsection shall be at least 12 feet wide.

50

50

## Access Aisles

### Wisconsin Statutes 346.503 (1m) (am)

- When at least 4 but less 20 disabled parking spaces are provided, at least one disabled parking space shall have an adjacent access aisle.
- When more than 20 disabled parking spaces are provided, 10 percent of disabled parking spaces shall have an adjacent access aisle.
- Access aisle shall be at least 96 inches wide and clearly marked.
- This only applies to work completed after August 1, 2014.

51

51

## What is Missing?

### Wisconsin Statutes

- Location of disabled parking within a parking facility.
- Accessible route to either an accessible entrance or pedestrian access route.
- Clear open space adjacent to parking meters or parking pay stations.

52

52

## Which should standard/guideline or statute be used?

ADA Regulations 28 CFR § 35.103 Relationship to other laws.

**(b) *Other laws.*** This part does not invalidate or limit the remedies, rights, and procedures of any other Federal laws, or State or local laws (including State common law) that provide greater or equal protection for the rights of individuals with disabilities or individuals associated with them.

53

53

## Questions

- Use Zoom's raise-hand feature.
- Unmute and ask your question.
- Enter question in chat with your email address.
- Thank you for joining today!

54

54

## Resources

- [ADA.gov](https://www.ada.gov) - U.S. Department of Justice, Civil Rights Division
- U.S. Access Board
- National Network of ADA Centers
- Great Lakes ADA Center
- Wisconsin ADA Coordinators Association

55

55

Thank You!

56

56